

BREEO

DOUBLE FLAME 24" SMOKELESS FIRE PIT SPECIFICATIONS

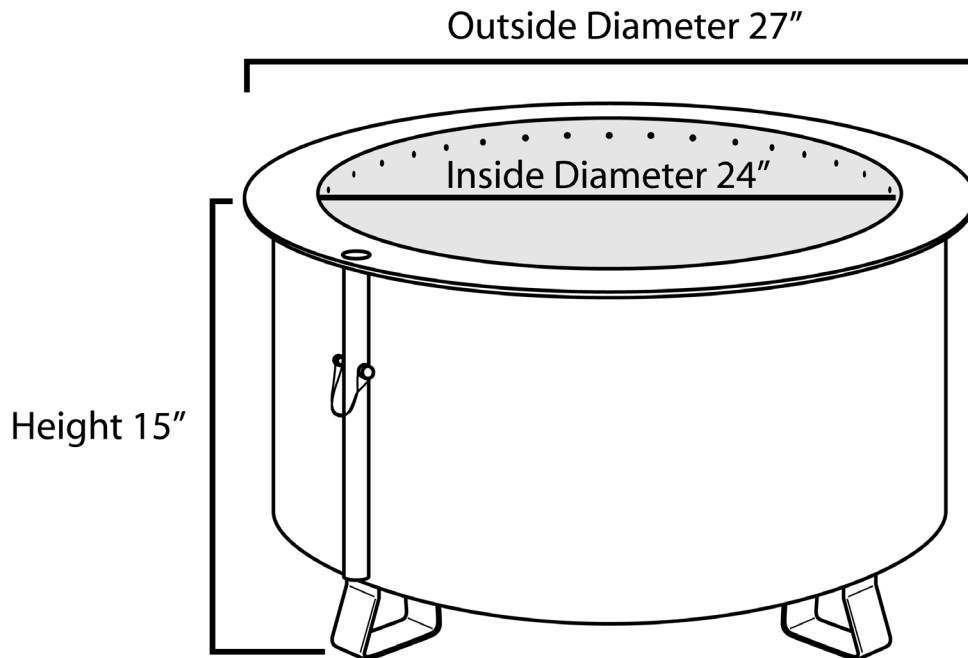

Material: Steel, Painted With a Black High-Temp Grill Paint
OR
304 Stainless Steel

Inside Diameter:	24 in.	Inside Height:	11.5 in.
Outside Diameter:	27 in.	Total Height:	15 in.
Flange Width:	2.5 in.		

Weight:
Steel: 62 lbs.
Stainless Steel: 57 lbs.

Double Flame 24" Smokeless Fire Pit
SKU: DF-24SLFP OR DF-24SLFP-SS

All Breeo Smokeless Fire Pits have been handcrafted in the USA.